

# The Mercedes-Maybach S-Class



MAYBACH



Mercedes-Benz

## The Essence of luxury.

The new Mercedes-Maybach S-Class.

The S-Class is already renowned the world over, as the finest luxury sedan. Our engineers have elevated the luxury, the workmanship and the power of this already incomparable sedan, to an unprecedented level with the Mercedes-Maybach S 600. An automotive experience that blurs the lines between science and art. It's Biturbo engine allows this extended piece of finesse to perform with rare athleticism. While its rear cabin, which is the world's quietest, has handcrafted surfaces wrapped in sumptuous finishes and textures. These are as much beautiful to the touch, as they are to the eye.

All you connoisseurs sit back. Welcome the Mercedes-Maybach S 600 to India.



The pinnacle of refined motoring.  
The new Mercedes-Maybach S-Class.







You have a meeting  
with unique refinement.

In the new Mercedes-Maybach S-Class, luxury means more than timeless design, the finest leather and unrivalled comfort. It is also a key element of the business plan: a confident display of entrepreneurial virtues such as performance and success. The new Mercedes-Maybach S-Class delivers perfect proof of your ability to combine outstandingly high-quality work with the more pleasurable things in life. For many, the true definition of luxury.

\*Please read the disclaimer. 2x2 seats available only for Mercedes-Maybach S 600.



When can a moment not be surpassed? Or a car? Intense light showcases the immaculate trim. Richly contrasting materials blend to form harmonious surfaces. Exclusive design sparkles with optimum functionality and a predilection for detail. Your glance sweeps through the generous space and your hands rest for a few seconds on the timelessly classic leather of the seats. Before you alight, sure in the knowledge that the perfect day is simply a question of the right vehicle.





Mercedes-Benz Intelligent Drive.  
Looking ahead. Thinking ahead.

Welcome to the automotive future. Which arrived a long time ago as far as the Mercedes-Maybach S-Class is concerned. Lay your hands on the steering wheel and all your senses will link up. The cutting-edge on-board and external sensor systems will see ahead into the immediate future for you, draw conclusions for you, react at lightning speed and thereby prevent accidents. Thanks to a stereo camera, powerful processors, technical

assistant systems and years of unstinting research. A further milestone from Mercedes-Benz along the path towards greater safety and comfort in road transport and a significant step towards autonomous driving. What will the future bring? The more research we do, the more perspectives that open up. That's how it is with visions. There comes a time when you need a new one. Of and for the future.



## Masterpiece of chassis engineering

What do you call something that's ground-breaking? Something that's prepared to leave the tried and trusted behind, to reinvent it. Knowing that the real challenge always lies ahead. Revolutionary? Innovative? Visionary? We call it MAGIC BODY CONTROL. This chassis technology sets itself up in advance to deal with the road conditions ahead. One could almost say, it relieves the road of its pockmarks and

imperfections. This view of the immediate future is achieved through a stereo camera, positioned behind the rear-view mirror, which observes the road from two perspectives.

On the basis of these image data and the information on the driving conditions, the system calculates the appropriate strategy in a fraction of a second – that is, in real time.



## Burmester® high-end 3D surround sound system with 24 loudspeakers

24 specially designed high-performance loudspeakers, 24 amplifier channels with a total system output of 1540 watts, an additional booster rated at 400 watts for the subwoofer in the boot and technologies developed specifically for the vehicle guarantee unprecedented listening enjoyment. A combination of analogue and digital elements produces an extraordinarily expressive and fascinating 3D sound – the Burmester “feel-good sound”. With the 3D surround sound system, passengers are able to experience and enjoy mono, stereo and 5.1 music signals three-dimensionally in the vehicle. This is done with the help of special Burmester algorithms and three speakers integrated into the roof liner. The VIP setting makes it possible to adjust the sound individually for the driver, front passenger and passengers on the left and right in the rear. To suit personal tastes, individual sound adjustments can be made with the five sound presets “Pure”, “Easy Listening”, “Live”, “Surround” and “3D Surround”. In addition to the acoustic highlights, the Burmester® high-end 3D surround sound system impresses with visual effects: two tweeters installed in the mirror triangles of the front doors as well as two in the rear doors move into the most favourable position when the system is switched on, lighting up in one of seven freely selectable colour shades if the ambient lighting is active.



The Burmester® high-end 3D surround sound system delivers a unique three-dimensional audio experience.

## AIR-BALANCE package – personal fragrance and clean, fresh air

The vehicle interior can be fragranced according to personal preferences with the AIR-BALANCE package. It offers five high-quality interior fragrances to suit personal preference and mood. The fragrance can be easily changed by exchanging the fragrance flasks used in the generator in the glove compartment. The intensity and duration of the fragrancing are adjustable. The fragrance is discreet, given off gently and is rapidly dissipated after switching off. The smell of the interior is not permanently changed, nor are the fragrance molecules deposited on fabric surfaces or clothing. Oxygen ionisation of the interior air is a further function of the AIR-BALANCE package. Enriching the air with negatively charged oxygen ions has a refreshing effect. At the same time certain viruses, bacteria and spores can be reduced. In addition, a filter system with two activated charcoal fine-particle filters, clean the outside air transported into the vehicle interior by the air-conditioning system. While the particle filter system traps the dust, the layer of activated charcoal also reduces peak levels of gaseous emissions

such as sulphur dioxide, nitrogen oxides or aromatic hydrocarbons until they are no longer perceived as unpleasant.

### The five fragrances for the AIR-BALANCE package:

- AGARWOOD with Maybach lettering on the fragrance flask (exclusively for Mercedes-Maybach S-Class)

### Optional fragrances:

- NIGHTLIFE MOOD
- DOWNTOWN MOOD
- SPORTS MOOD
- FREESIDE MOOD



## Rear Seat Comfort Package

The best possible seating comfort on the outer rear seats is ensured by multi-contour seats, which incorporate inflatable air chambers for even more individual adjustment. That is why they are recommended by the AGR spinal health organisation. The drive dynamic function improves lateral support and the ENERGIZING massage function enhances well-being – also with added heat if required, on the principle of a relaxing hot-stone massage.

The rear passengers are able to adjust the air chambers in the lumbar and shoulder areas individually to suit their personal physique. A lumbar adjustment gives additional support to the spine. When on the move, the side bolsters automatically and dynamically adapt to vehicle movements to provide even better lateral support on winding roads and when driving in a sporty manner. The ENERGIZING massage function stimulates and relaxes the back muscles as required, with 14 air chambers, six programmes and two intensities. This function helps to ensure a relaxed and refreshed arrival after a long journey. The combination of gentle pressure and pleasant warmth is particularly beneficial.

Features of the Rear Seat Comfort package:	
Multi-contour rear outer seats with ENERGIZING massage function and dynamic function	Massage function using 14 air chambers in the backrest
Seat side bolsters are adjusted by an air chamber in each	Massage heating panels in the spinal area
	Fast-action seat heating plus



## Exclusive package – the pleasure of excellence

The stylishly coordinated combination of high-quality appointments meets highest expectations with regard to comfort, quality and design. Generous use of exclusive handcrafted nappa leather and large areas of wood trim enhance the exclusivity of the interior. The effect is heightened by other fine details such as the backlit door sill panels with "Mercedes-Benz" lettering, the stainless-steel boot sill and the roof lining and sun visors, which are covered in elegant DINAMICA microfibre.



## Night View Assist Plus – seeing more for safer driving at night

Only 20% of road traffic is at night-time, but 40% of all fatal accidents occur during this period. Night View Assist Plus enables drivers to detect pedestrians or larger animals sooner in the dark. They are clearly highlighted in the Cockpit Display. To do this the system illuminates the road ahead with two anti-dazzle infrared lamps. With the help of an infrared camera located behind the windscreen, the entire area within high-beam headlamp range is shown as a crystal-clear greyscale image. A thermal imaging camera in the radiator grille is able to give a precise warning by distinguishing between irrelevant objects such as traffic sign combinations or bushes and relevant objects such as pedestrians or large animals. The latter are highlighted in colour by small "photo mounts". The spotlight function enables endangered pedestrians to be flashed at several times, so that the driver registers them even more quickly and the former recognise the danger. As standard, the night view image only appears automatically when a hazardous situation is recognised.



\*Please read the disclaimer.

## PRE-SAFE® rear package – more comfort and better protection

Illuminated seat belt buckle extenders make seat belt fastening easier for passengers on the outer rear seats, and can tension the seat belts in critical situations to increase occupant protection. The beltbag, a type of inflatable belt strap, reduces the load exerted on the chest during a crash. When passengers enter the rear, the belt buckles extend upwards by 70 mm and light up. After the seat belt is fastened, the belt buckles return to their original position while individually adjusting the seat belt fit. If the PRE-SAFE® system recognises a critical driving situation, the belt buckles are retracted by 40 mm to tension the seat belts and fix the occupants in place as firmly as possible for a collision. If an impact occurs, the beltbag fitted with tear seams is inflated to almost three times its width. The loads acting on the occupants are distributed over a wider area, correspondingly reducing the loads on the chest area. After an accident the belt buckles light up and extend upwards to relieve the belt tension. This facilitates the rescue of the occupants.

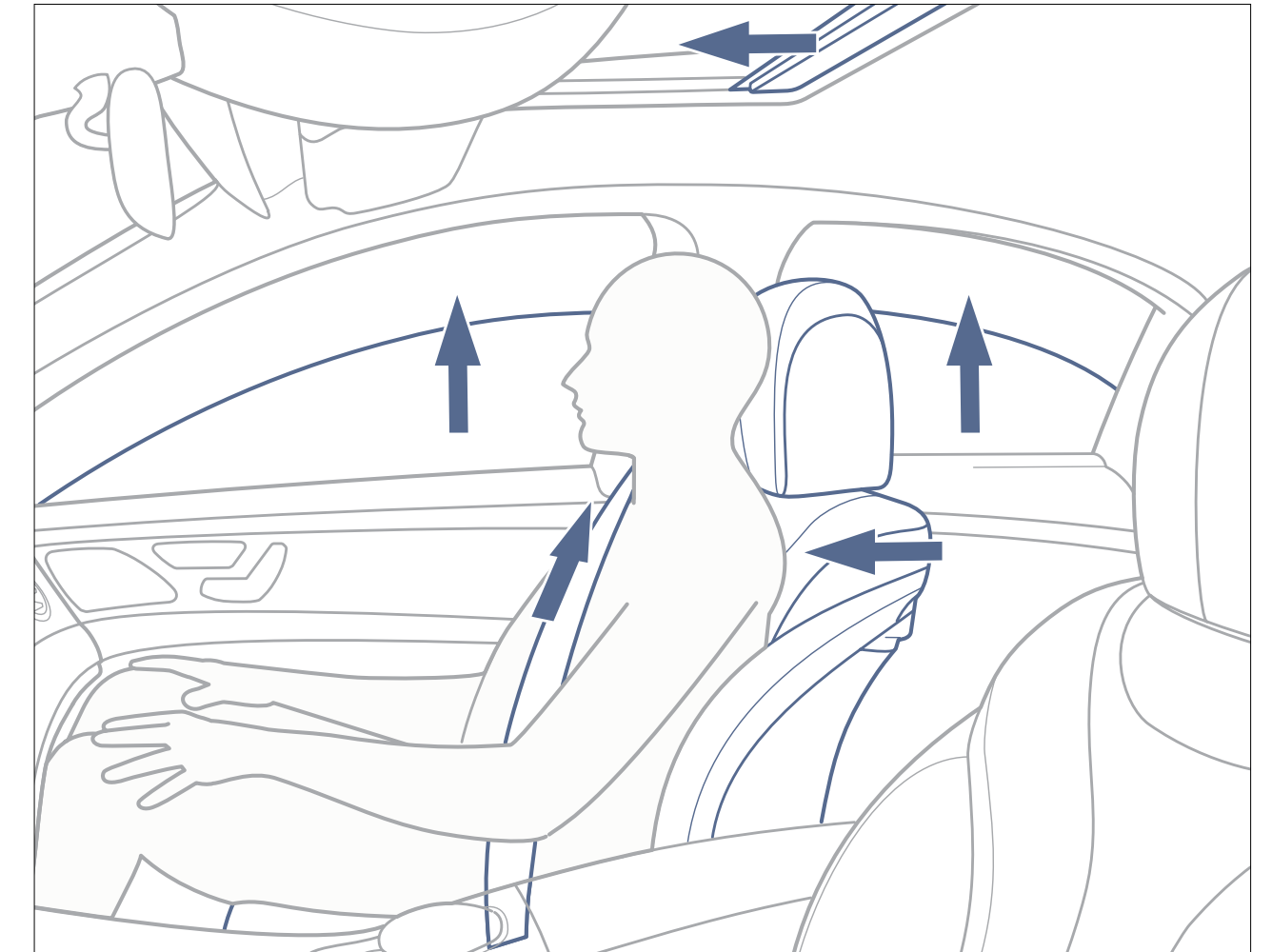

## What makes a car a Mercedes-Maybach?

Deep-rooted traditions: in our case, it is innovative traditions that run deep. We have continually gone down previously uncharted avenues. Milestone by milestone. These ventures spawned the first vehicle with a crumple zone, the first ABS, the first diesel passenger car. The first car. But rather than wallowing in the past, let us look to the future.

**Mercedes-Benz Intelligent Drive** – on the road to accident-free driving. We develop intelligent assistance systems which actively support the driver and noticeably relieve their workload. They monitor and analyse the vehicle's surroundings and handling characteristics – and warn the driver if they identify any critical situations. When necessary, some of the systems are able to intervene to take corrective action. Potential dangers are identified earlier than ever – and ever more frequently avoided as a result. Discover the fascinating world of Mercedes-Benz Intelligent Drive at [www.mercedes-benz-intelligent-drive.com](http://www.mercedes-benz-intelligent-drive.com)

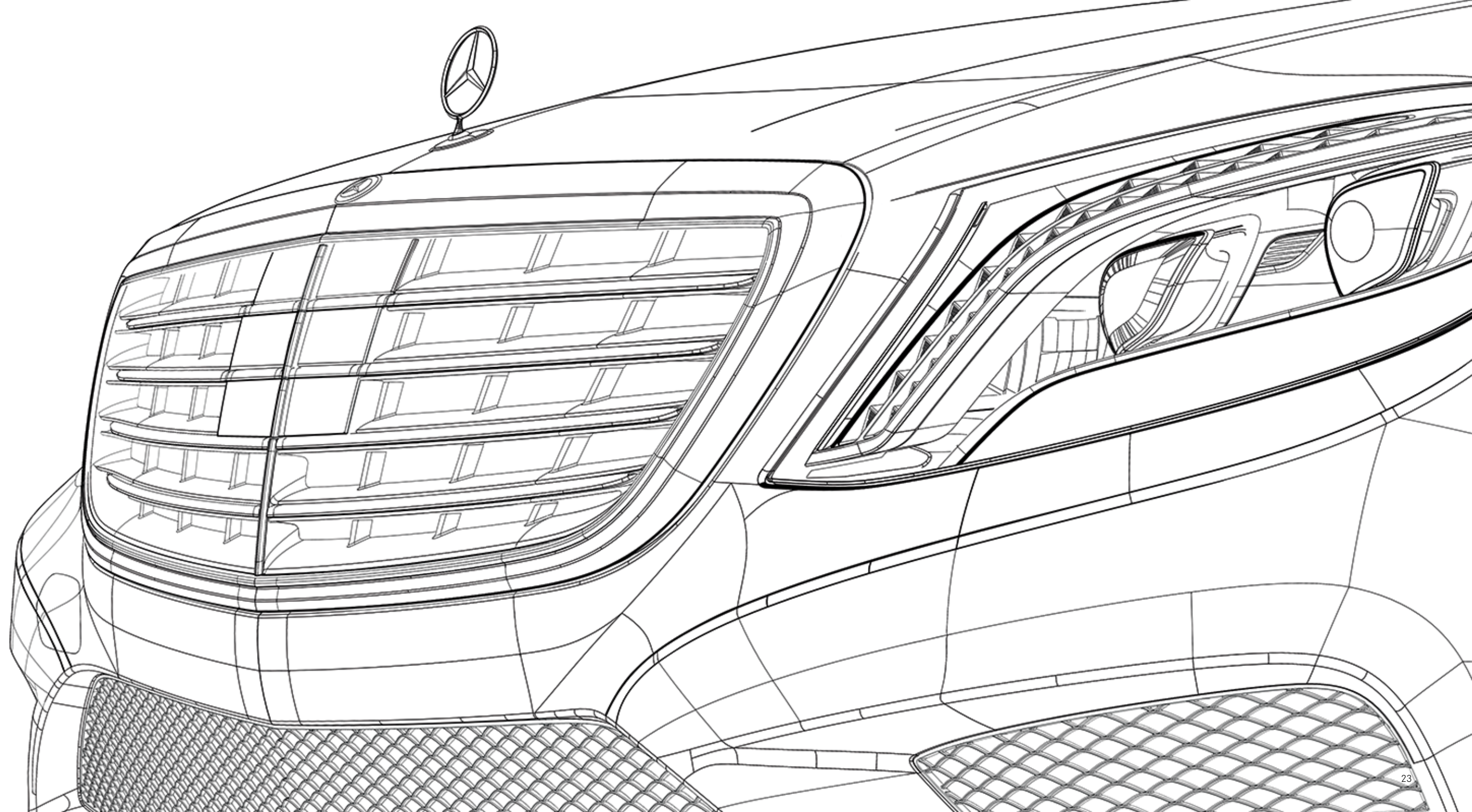

## Engines

The rule of the road today: you can't have refinement without efficient technologies. Mercedes-Benz petrol engines are therefore lighter and measure out fuel extremely precisely. In this way they bring together a sense of responsibility and commitment, without compromising on driving enjoyment – no matter what drive system you opt for.

**V8 engine.** Refinement, driving pleasure and responsibility – embodied by the petrol engine with 338 kW (459 hp). Thanks to twin turbocharging and intercooling, the S 500 has huge reserves of power. The engine may give off its typical, unmistakably sonorous and cultivated sound, but fuel consumption stays exceptionally low.

**V12 engine.** At the summit of the engine range the V12 biturbo engine combines fast responsiveness with environmental awareness. This is how the V12 engine saves fuel – yet is generous with superlatives: 830 Nm of torque is on tap from below 2000 rpm. Its 390 kW (530 hp) accelerate, the car from a standstill to 100 km/h in a mere 5.0 seconds.

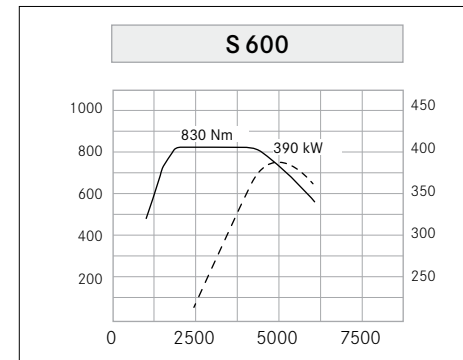
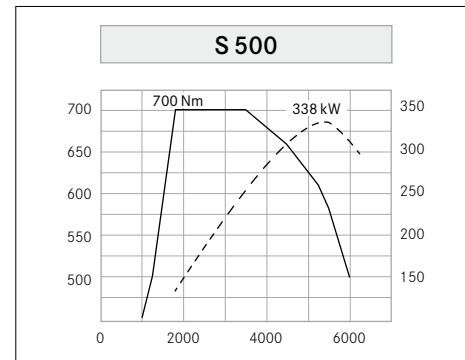

— Torque (Nm) Engine speed (rpm) - - Output (kW)  
The 8-cylinder petrol engine is powerful, refined and efficient.

— Torque (Nm) Engine speed (rpm) - - Output (kW)  
The 12-cylinder petrol engine – supreme power delivery, maximum efficiency.

## Transmissions

The consumption and efficiency-optimised 7G-TRONIC PLUS automatic transmission and the innovative 9G-TRONIC transmission stand out by virtue of their high level of efficiency, ultra-smooth gear shifting, dynamic response and reduced noise levels.

**9G-TRONIC** (standard for Mercedes-Maybach S 500). The 9-speed automatic transmission changes between the gears quickly and barely perceptibly, offering an extremely high level of gearshift quality. The high overall efficiency reduces fuel consumption and emissions, making an important contribution to an ecological driving style without compromising on driving enjoyment.

**7G-TRONIC PLUS** (standard for Mercedes-Maybach S600). The 7-speed automatic transmission combines a high level of comfort with driving pleasure and efficiency. The 7 forward gears allow a wide ratio spread with low engine speed increments between the individual gears. This leads to fast-responding, fuel-efficient gear changes with pleasantly smooth transitions.



\*Please read the disclaimer.



\*Please read the disclaimer.

## Chassis and suspension

The Mercedes-Maybach S-Class is fitted with the latest-generation, enhanced AIRMATIC suspension system as standard. The innovative MAGIC BODY CONTROL – a technological milestone, premiered in the S-Class – is available for Mercedes-Maybach S 600.

**AIRMATIC.** Whether it's setting is sporty or comfortable, the AIRMATIC air suspension with it's continuously variable damping system adjusts the damping power at every wheel to suit the current situation and the condition of the road. The all-round self-levelling integrated into the system ensures virtually constant ground clearance, even when the car is laden, and thus more stability and comfort.

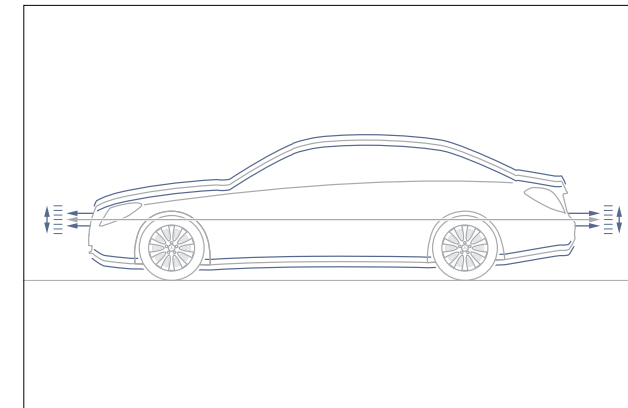

The stepless air suspension AIRMATIC with all-round self-levelling ensures excellent agility and maximum ride comfort.

**Crosswind Assist.** In strong, gusty crosswinds there is a danger of the vehicle being blown off-course. Crosswind Assist is able to recognise this and help the driver to keep the vehicle on course. Using the ESP® sensor system, course-correcting brake actuation is performed automatically. This brake actuation takes place at the wheels on the side of the vehicle facing the crosswind. The resulting yawing motion around the vertical axis counters the effect of the crosswind. This reduces track offset considerably. In this way Crosswind Assist gives the driver a greater feeling of safety and helps to avoid inappropriate reactions, especially when sudden gusts strike the vehicle.

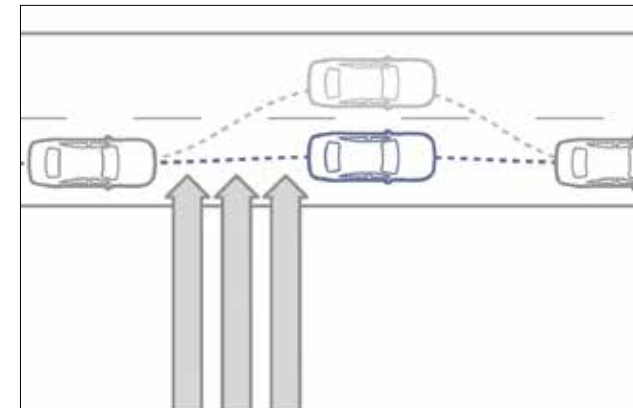

**MAGIC BODY CONTROL** (standard for Mercedes-Maybach S 600). This dynamics-oriented suspension system already adjusts to surface undulations before the vehicle drives over them. This is made possible by the combination of the active springing of the suspension system with the ROAD SURFACE SCAN function. With the aid of a stereo camera the condition of the road surface ahead is captured in detail. From the data gleaned the system calculates in a split second the correct strategy for adjusting in advance the damping of each wheel so as to deal in the best possible way with the unevenness ahead.



**THERMOTRONIC automatic climate control.** The front and the rear passengers enjoy even greater climate comfort thanks to the 4 Zone conditioning system with 2 climate zones for the rear seats. The temperature and air distribution can be individually set using a control panel on the rear of the centre console.



\*Please read the disclaimer.

## Mercedes-Maybach.

The exterior. Effortless superiority is the best calling card.

Part of the fine art of diplomacy is elegantly playing to your strengths. As “The essence of luxury”, the Mercedes-Maybach S-Class achieves this in inimitable fashion.

The radiator grille with its three distinctive twin louvres and vertical chrome panels is an unmistakable statement of exclusive design, while the new-look rear doors and the

fixed triangular windows are clear indicators of the luxurious spaciousness within thanks to the 200 mm longer wheelbase. The chrome inserts at the B-pillars, the side triangular windows and the rear apron further add to the elegant appearance of the luxury saloon. As do the two standard-fit twin tailpipe trims and the available forged wheels.

Driving comfort has no upper limits in the new Mercedes-Maybach S-Class. As evidenced by the panoramic sliding sunroof with MAGIC SKY CONTROL (optional for Mercedes-Maybach S 600). The roof changes colour at the touch of a button from dark to transparent and vice-versa in a matter of seconds. When the large glass surfaces turn transparent, the passengers can enjoy an exceptionally light and friendly atmosphere in the interior.



\*Please read the disclaimer.



\*Please read the disclaimer.





\*Please read the disclaimer.

Luxuriously refined travel – the interior of the Mercedes-Maybach S-Class.

## Mercedes-Maybach.

The interior. Drive your business forward while you lean back and relax.

The interior of the new Mercedes-Maybach S-Class creates an atmosphere that makes it easy for you to feel really good.

The Mercedes-Maybach S-Class is 207 mm longer than the long-wheelbase S-Class. So you can enjoy even more space, particularly in the rear. Thanks to the Executive seats on the right and left, which can be moved into a reclined position of up to 43.5°. An extending thigh support provides for further enhanced comfort. Experience a unique feeling of space – further enhanced by the extended ambient lighting, the third window behind the C-pillar and the panoramic sliding sunroof.



Exclusivity right down to the last detail – “Maybach” lettering and elegant IWC analogue clock.



\*Please read the disclaimer.

## Mercedes-Maybach S-Class Standard Features

### Executive seats with thigh support

With the Executive seats the rear-seat passengers can enjoy even long journeys in absolute relaxation. The seats can recline into a comfortable lying position at the push of a button. In combination with the electrically extending footrest on the front-passenger side this creates a comfortable surface for refreshing sleep.



2 x 2 seats optional with Mercedes-Maybach S 600 only

### Individual entertainment system in the rear

Two 25.4 cm (10-inch) displays and wireless headphones provide brilliant picture and sound quality, giving passengers in the rear their very personal entertainment programme.



\*Please read the disclaimer.

## Mercedes-Maybach S-Class Standard Features

### Memory package for driver and front passenger

The Memory package is especially convenient if the vehicle is used by more than one person. Up to three different positions for the electrically adjustable front seats, steering column and exterior mirrors can be stored and retrieved at the touch of a button.



\*Please read the disclaimer.

### Electrically-adjustable rear seats including memory function

Made-to-measure travelling comfort in the rear is ensured thanks to the electrically adjustable seats. The backrests of the two outer luxury seats can be reclined to an angle of up to 37°. Three preferred positions can be stored via the memory buttons.



## Mercedes-Maybach S-Class Standard Features

### Active Parking Assist with PARKTRONIC

The system makes it easier when searching for a parking space and when entering parallel and end-on parking spaces and leaving parallel spaces. The system automatically steers the vehicle into parking spaces, relieving the driver of the work of steering and braking.



### COMAND ONLINE

Navigation, telephone, audio, video, internet – with the COMAND Online control and display system the driver is able to keep these and many other functions in view and under control. Information is shown in high-resolution and in colour on the large 31.2 cm media display. Operation is simple and intuitive.



\*Please read the disclaimer.

## Mercedes-Maybach S-Class Standard Features

### Panoramic sliding sunroof

With its large glazed areas, this roof system ensures a particularly bright and welcoming ambience in the interior. It consists of a fixed panoramic glass rear section and an electrically operated sliding glass front section for ventilation of the interior as required.



### KEYLESS-GO

With this convenient access and drive authorisation system, the driver only needs to carry the key with him. All the doors can be unlocked and locked by touching the door handle, without having to hold the key. The engine can also be switched on and off conveniently by pressing the start/stop button in the ignition lock.



\*Please read the disclaimer.

# Mercedes-Maybach S 600 Standard Features

## MAGIC VISION CONTROL

The adaptive windscreen wiper system allows the driver the best possible visibility even during the wiping process. The washer fluid is sprayed directly in front of the wiper blades and wiped away without delay. This is done via small nozzles in a distribution rail above the wiper blade. Thanks to this aimed distribution, washer fluid consumption is reduced by up to 50 percent. MAGIC VISION CONTROL automatically adjusts the amount of washer fluid dispensed to the prevailing conditions, e.g. the ambient temperature or degree of soiling. When operating while the panoramic sliding sunroof is open, the amount of washer fluid is actively reduced to avoid spraying the interior. Heating of the washer fluid reservoir and all the hoses effectively protects the system against icing-up, ensuring easier cleaning of the windscreen even in low temperatures. The heated wiper blades also prevent the blades from becoming clogged with snow.



## Head-Up display

Key driver information at a glance, without the driver having to take their eyes off the road – this is a feature made possible by the Head-up display. It projects a virtual image measuring approximately 21 x 7 cm into the driver's field of vision, which appears to float around 2 metres in front of him/her, above the bonnet. The information is displayed in high-resolution and in colour.



## SplitView

The 31.2 cm COMAND Online display enables the front passenger to enjoy films in brilliant picture quality while the driver e.g. follows the navigation instructions. This is made possible by SPLITVIEW, which is able to show different content simultaneously on the same display depending on the viewing angle. A high-quality radio headset treats the front passenger to first-class sound without disturbing the driver. The front passenger has convenient access to the entertainment source of his or her choice by remote control – movies on DVD, radio and internet. Content from mp3 players, game consoles or an iPod® is also available via the aux-in port.



\*Please read the disclaimer.

## Anti-Theft Protection package

A combination of different security features helps to protect the vehicle effectively against break-in, theft and towing-away. The anti-theft alarm system (ATA) gives an audible warning with an alarm siren and a visual warning of break-in and theft, for example, unauthorised opening of the vehicle doors, boot lid or bonnet. The system automatically is rendered active by locking the vehicle using the electronic key. The anti-theft alarm system is deactivated as soon as the driver unlocks the vehicle with the electronic key. Motion in the vehicle interior triggers a visual and audible alarm if infrared interior monitoring is activated. It too, automatically is rendered active by locking the vehicle using the electronic key. If the vehicle inclination changes, when the tow-away protection system is switched on a visual and audible alarm is triggered. This can occur if one side of the vehicle is raised.

## Mercedes-Maybach S 600 Optional Features

### Luxury Package 1

#### Refrigerated compartments

Cooled food and drinks always at hand – the refrigerated compartment provides this treat to passengers in the rear. It is elegantly integrated into the rear armrest and has a capacity of approx. 8.5 litres.

#### Champagne flutes

A drive in a quite exceptional vehicle can be celebrated in style with the two high-quality, silver-plated champagne flutes.



Champagne flutes, only available with 2x2 seats and refrigerated compartment

### Luxury Package 2

#### 2x2 Seats. Folding tables in the rear

With the two high-quality folding tables in the interior colour, the business console of the First-Class rear suite can be converted into an office desk in seconds. The stowage trays provide space for a notebook or documents, allowing comfortable working. The folding tables are integrated into the stowage compartment in the business console, and can be easily folded out manually once the armrest has been opened.



### Comfort Feature

#### Panoramic sliding sunroof with MAGIC SKY CONTROL

MAGIC SKY CONTROL creates an open-air feeling at the push of a button. The 2-section panoramic sliding sunroof changes from dark to transparent or vice versa within a few seconds. The transparency of the two sections of the roof can be changed independently for each section.



\*Please read the disclaimer.

## Upholstery and Trim - Mercedes-Maybach S 500

### UPHOLSTERY

Exclusive Nappa Leather Silk beige/ Espresso brown

Exclusive Nappa Nut Brown/ Black

Exclusive Nappa Leather Porcelain/ Black

Exclusive Nappa Leather Black/ Black

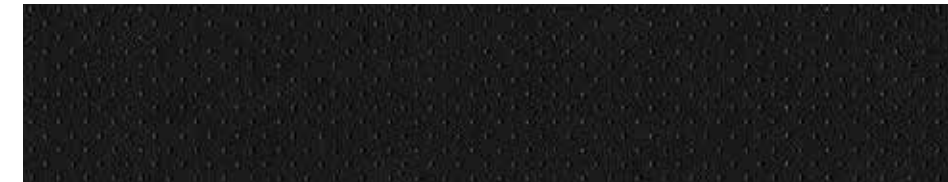

### TRIM

designo brown high gloss sunburst myrtle wood trim



## Paintwork and Alloy - Mercedes-Maybach S 500

### PAINT

Obsidian Black

Diamond White

Cavansite Blue

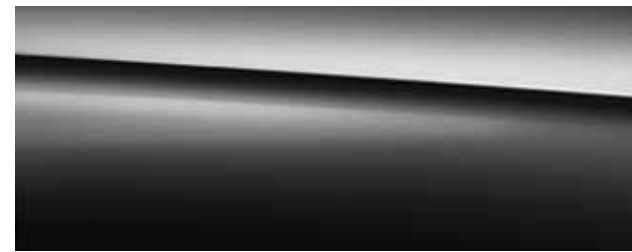

Ruby Black

Diamond Silver



### ALLOY

48.3 cm (19-inch) 5 twin spoke light-alloy wheels



## Upholstery and Trim - Mercedes-Maybach S 600

### UPHOLSTERY

Exclusive Nappa Leather Black

Exclusive Nappa Leather Silk Beige/ Espresso Brown

Exclusive Nappa Leather Crystal Grey/ Seashell Grey

Exclusive Nappa Leather Porcelain/ Black

Exclusive Nappa Leather Nut Brown/ Black



### TRIM

High-gloss brown burr walnut wood trim

High-gloss black poplar wood trim

designo metallised ash wood trim

designo brown high gloss sunburst myrtle wood trim

designo black piano lacquer trim

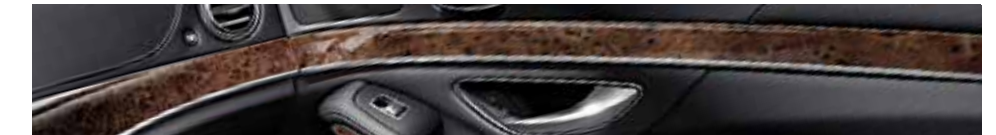

## Paintwork and Alloy - Mercedes-Maybach S 600

### PAINT

Magnetite Black  
Obsidian Black  
Iridium Silver  
Canvasite Blue  
Peridot Brown

Ruby Black  
Diamond Silver  
Anthracite Blue  
Diamond White

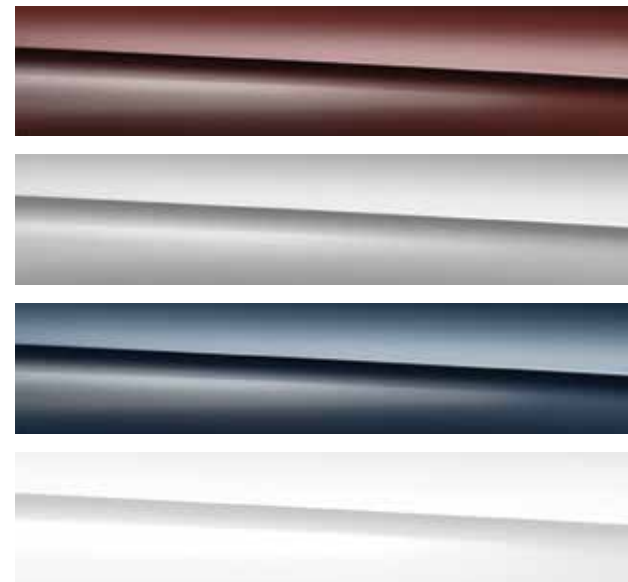

### ALLOY

48.3 cm (19-inch) multi twin spoke light-alloy wheels  
48.3 cm (19-inch) 5 twin spoke light-alloy wheels (optional)  
48.3 cm (19-inch) multi spoke light-alloy wheels (optional)



## Dimensions

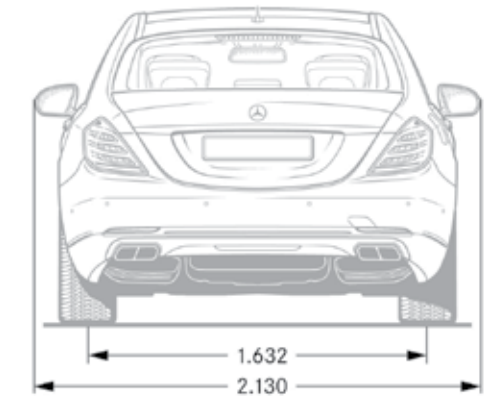
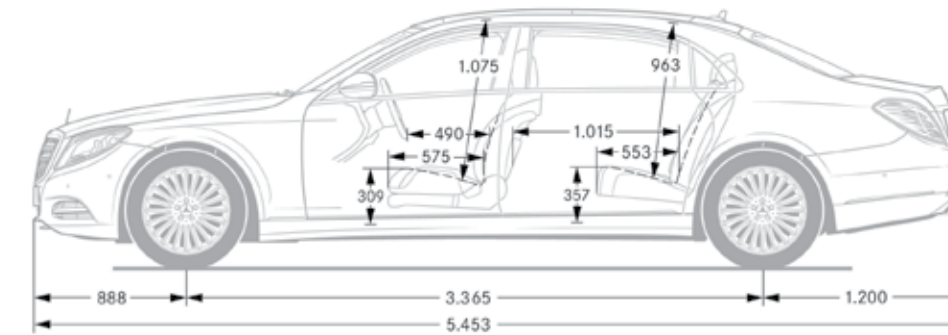
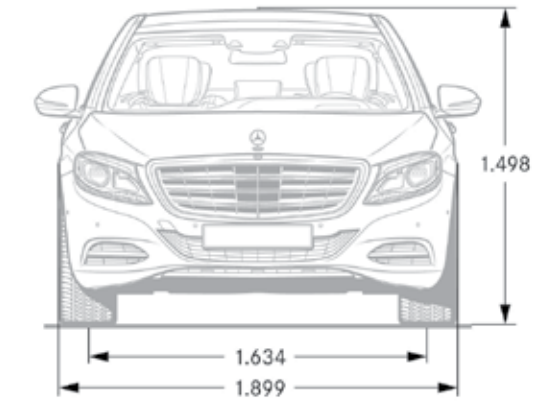
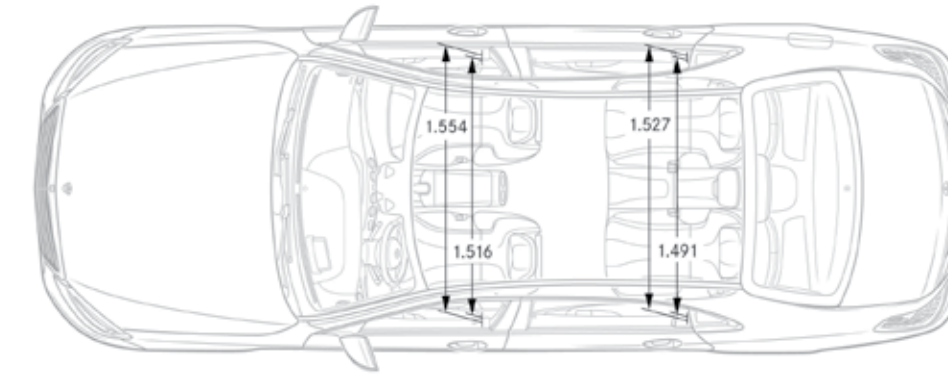

All dimensions are in millimetres. The dimensions shown are mean values and apply to standard-specification, unladen vehicles.

## Technical data.

	Mercedes-Maybach S 500	Mercedes-Maybach S 600
Arrangement/ No. of Cylinders	V8	V12
Total displacement (cc)	4663	5980
Rated output (kW [hp] @ rpm)	338 [459] @ 5250 - 5500	390 [530] @ 4900-5300
Rated torque (Nm @ rpm)	700 @ 1800 - 3500	830 @ 1900 - 4000
Top speed approx. (km/h)	250	250
Fuel	Petrol	Petrol
Tank capacity (L)/ incl. approx. reserve	80/8.0	80/8.0
Boot capacity (L)	500	500
Turning circle diameter (m)	12.9	12.9
Kerb weight (kg)	2280	2335
Permissible gross vehicle weight (kg)	2795	2815
L x W x H	5453 x 1899 x 1498	5453 x 1899 x 1498
Wheelbase (mm)	3365	3365

\*Please read the disclaimer.

## Service

The luxurious experience of driving a Mercedes-Benz is converted into a fulfilling ownership experience with a range of exclusive services and special programmes.

### Cost of Ownership

There has been a paradigm shift in the buying preferences of Indian consumers over the years, even for the luxury products. The purchase decision not only dwells around cost of acquisition but also the total 'Cost of Ownership' (COO). Amongst the key components of COO in cars are the routine service jobs and the unplanned repair expenses post the warranty period. We are now offering highly-affordable Service Packages and Extended Warranty Programmes which are the most competitive packages in its class. All in all, we provide you with a controlled Cost of Ownership while you benefit from the legendary Mercedes-Benz service quality.



Extended Warranty that guarantees complete peace of mind

### Experience complete peace of mind when you drive the Star

**STAR CARE** programme offers peace of mind for you during the warranty period and beyond. While our cars are covered for warrantable repairs of up to 3 years without any mileage limitations as standard, you can also buy STAR CARE Plus programme, offering 4<sup>th</sup> year extended warranty. Additionally, the programme enhances the resale value of your car.



**STAR EASE** service package gives you the freedom to relax behind the wheel and puts your mind at ease with its range of unique benefits such as defined cost of maintenance and priority handling. STAR EASE comprehensive package covers essential jobs related to periodic service (viz. oil, filters, consumables, etc.) along with coverage for brake pads, brake discs, wiper blades, wheel alignment and balancing for a contracted period. For further details on products and pricing, please contact your nearest Mercedes-Benz dealer.



The maintenance of your Star is just as peaceful as driving it

### On-Road Assistance Programme

As part of our ongoing commitment to you, Mercedes-Benz On-Road Assistance is designed to enhance your overall Mercedes-Benz ownership experience by providing you with 24-hour On-Road Assistance. Mercedes-Benz is the only luxury car manufacturer to offer round-the-clock On-Road Assistance for 3 years from purchase of the vehicle as a standard offering. Peace of mind motoring – guaranteed.



Always at your service

Conditions apply.





# India's Largest Luxury Car Network

It takes a keen sense of responsibility to provide the Best. Our large network is spread across the country in 39 cities with 80 outlets and is still growing. With world-class showrooms, state-of-the-art workshops and highly skilled personnel, experience the best wherever you go.



## DEALER CONTACT:

### NORTH & EAST:

**BHUBANESWAR:**  
Tristar Motors: 0-7852944100

**CHANDIGARH:**  
Joshi Autozone: 0172-5050500  
Panjab Motors: 0172-4290000

**DELHI:**  
Patel Auto Services, Rajendra Place:  
011-47626262/0-9810081048

**T & T Motors, Mohan Co-operative,**  
Mathura Road: 011-66574300/330  
Rajouri Garden: 011-66574400/430

**GHAZIABAD:**  
Silver Arrows: 0-9718200500

**GURGAON:**  
T & T Motors: 0124-4263060/62

**JAIPUR:**  
T & T Motors: 0141-4300000/05

**JAMSHEDPUR:**  
Tristar Motors: 0-7763815720/  
0657-6601601/02

**JALANDHAR:**  
Joshi Autozone: 0181-5004444

**KANPUR:**  
Smart Hoops: 0-8795663300

**KARNAL:**  
Berkeley Motors: 0184-3300000

**KOLKATA:**  
Benchmark Interkrafts: 1800 3000 3310

**LUCKNOW:**  
Smart Hoops: 0522-6004008/9

**LUDHIANA:**  
Joshi Autozone: 0161-5055000

**MOHALI:**  
Panjab Motors: 0172-4290000

**NOIDA:**  
Silver Arrows: 0-9999200500

### WEST:

**AHMEDABAD:**  
Benchmark Cars: 0-9377662000

**AURANGABAD:**  
B. U. Bhandari: 0-8605121333/  
0240-6452601/02

**BHOPAL:**  
Benchmark Cars: 0-9098233233

**GOA:**  
Counto Motors: 0832-2415122

**INDORE:**  
Benchmark Cars: 1800-3000-8844

**KOLHAPUR:**  
B. U. Bhandari: 0231-2661422/  
0-8380093555

**MUMBAI:**  
Auto Hangar, Prabhadevi: 022-67434362/63  
Auto Hangar, Andheri: 022-67106660/61

Metro Motors, Auto Hangar division  
Hughes Road: 022-66123500/11

Shaman Wheels, Off BKC: 022-24228787

**NAVI MUMBAI:**  
Shaman Wheels: 022-24228787

**NAGPUR:**  
Auto Hangar: 0-9223540191/  
07104-238180/1/2/3

**NASHIK:**  
Indisch Motoren: 0253-6645555

**PUNE:**  
B. U. Bhandari, Baner: 020-67212129  
Pune City Showroom: 020-67212131

**RAJKOT:**  
Benchmark Cars: 0-9377750050

**RAIPUR:**  
Auto Hangar: 0771-6537801/0-8518887155

**SURAT:**  
Benchmark Cars: 0-9377660066

**VADODARA:**  
Benchmark Cars: 0-9377390001

### SOUTH:

**BANGALORE:**  
Sundaram Motors: 080-22070720/21

Akshaya Motors, Mysore Road:  
080-22966300, 0-9066030989

Akshaya Motors, Koramangala:  
080-22966296, 0-9019326026

**CALICUT:**  
Bridgeway Motors: 0495-30 55555

**CHENNAI:**  
Trans Car: 044-40200300

Titanium Motors: 044-66498080/8181/8282

**COIMBATORE:**  
Sundaram Motors: 0422-2452020

**COCHIN:**  
Rajasree Motors:  
0484-2706332/2706432/2706134  
2607027/37/47

**HYDERABAD:**  
Mahavir Motors: 040-43403004

**MADURAI:**  
Sundaram Motors: 0452-2320433/  
0-9500966946

**MANGALORE:**  
Sundaram Motors: 0824-2214833/2215833/  
0-9008442155

**TRIVANDRUM:**  
Rajasree Motors: 0471-2380377/  
0-9846547551

**VIJAYAWADA:**  
Mahavir Motors: 0866-2082559/  
0-9885303004

## MERCEDES-BENZ CERTIFIED PRE-OWNED CARS:

**AHMEDABAD:**  
Benchmark Cars: 0-9016665000

**BANGALORE:**  
Akshaya Motors: 0-9019944044  
Sundaram Motors: 080-22070746/  
0-9880662051

**CHANDIGARH:**  
Joshi Autozone: 0-9878941930/ 0172-  
5050500/510

**CHENNAI:**  
Transcar: 0-9841049994

**DELHI:**  
T&T Motors, Mathura Road: 0-9711774424  
T&T Motors, West Delhi: 0-9711112243

**GHAZIABAD:**  
Silver Arrows: 0-9718200500

**HYDERABAD:**  
Adishwar: 0-7799633004

**KOCHI:**  
Rajasree Motors: 0-9846547311

**MOHALI:**  
Panjab Motors: 0172-4290000

**MUMBAI:**  
Autohangar India: 0-9223546204,  
0-9223547099

Shaman Wheels: 0-9619023450/ 022-  
69543333

**PUNE:**  
B U Bhandari: 020-67212172/0-8605118555

## AMG PERFORMANCE CENTERS:

**BENGALURU:**  
Sundaram Motors: 080-22070720/21

**DELHI:**  
T&T Motors: 011-66574309

**HYDERABAD:**  
Mahavir Motors: 0-9885033004/  
0-9885653004

**MUMBAI:**  
Auto Hangar: 022-67434360/61/65

**PUNE:**  
B.U. Bhandari: 020-67212131/0-8554055555

Our national toll-free no.:  
**1800 102 9222**  
One Call. All Answers.

For a complete list of  
Mercedes-Benz outlets,  
please explore the dealer locator  
tab on [www.mercedes-benz.co.in](http://www.mercedes-benz.co.in)

**Mercedes-Benz India Private Limited:** E-3, MIDC Chakan - Phase III, Chakan Industrial Area, Kuruli & Nighoje, Tal: Khed, Pune - 410 501 (India)  
Toll free No.: 1800 102 9222. e-mail: customerconnect@daimler.com, **website: [www.mercedes-benz.co.in](http://www.mercedes-benz.co.in)**

**Please note:** This brochure is intended for general information, description and illustration of the Product including optional functions and equipment and may not be specific to a Product since specification of a product may change from time to time. Optional features, functions and equipment etc. may not be present in the Standard or Variant Product or Special Edition Product. Further, Standard specifications of a product may also vary from time to time. Colours may differ from those shown in pictures in the brochure, owing to printing. Mercedes-Benz India reserves the right to make changes, at any point of time, without prior notice, in design, colours, materials, components, equipment, specifications, features, functions, make and models etc. The information given in this brochure shall be regarded as accurate at the time of going to print and may vary thereafter due to any developments or any other reason. Interested parties should confirm with the Authorised Dealer about the correct specification of the product they desire to purchase. For the latest authentic information and updates, kindly contact your nearest Authorised Dealer.

All title, ownership rights and intellectual property rights in and relating to this brochure / magazine or publication material or any copies thereof including but not limited to copyright, logos, names, trademarks, service marks, design, text, images, links, concepts and themes are owned by Daimler AG and/or its subsidiaries collectively or used under authorised license by the Daimler AG. Any reproduction, transmission, publication, performance, broadcast, alteration, license, creation of derivative works or other use in whole or in part in any manner without the prior written consent of the Daimler AG is strictly prohibited.

Month of going to press: September, 2015. Mercedes-Benz cars: The Mercedes-Maybach S-Class meets Bharat Stage IV equivalent emission norms.

CIN - U34102PN1994PTC083160